

# 8.0 – TECHNICAL SPECIFICATIONS + REFERENCES

## TABLE OF CONTENTS

8.1 – TECHNICAL SPECIFICATIONS.....	P. 8-3
8.2 – MATERIAL SAFETY DATA SHEET.....	P. 8-20
8.3 – RECOMMENDED INDUSTRY PRACTICE FOR PLACING REINFORCING BARS .....	P. 8-23
8.4 – STANDARD PRACTICE - SPLICING & DOWELS....	P. 8-24
8.5 – LOGIX R-VALUES.....	P. 8-27

T E C H N I C A L   S P E C I F I C A T I O N S   +   R E F E R E N C E S



# 8.1 – TECHNICAL SPECIFICATIONS

(CSI Specifications for LOGIX are available at [www.logixicf.com](http://www.logixicf.com))



Updated 07/23/14

## LOGIX INSULATED CONCRETE FORMS MATERIAL PROPERTY DATA SHEET

This document is intended for general information purposes only regarding specifications for Logix Insulated Concrete Forms (herein referred to as Logix ICF). Technical specification sheet, as per Construction Specifications institute (CSI) formatting, can be downloaded at [www.logixicf.com](http://www.logixicf.com).

### 1 PRODUCT DESCRIPTION

- Logix ICF consists of two flame-resistant EPS boards separated by polypropylene webs.
- Logix ICF consists of solid form units (LOGIX Pro Forms) or knock-down forms (LOGIX KD Forms) or a combination of both Logix form and Logix KD forms, referred to as LOGIX Hybrid Forms.
- The EPS foam boards are a minimum 70 mm (2.75 inch) thick, and can range in thickness of 70 (2.75 inches), 102 (4 inches), 127 (5 inches), 152 (6 inches), 178 (7 inches) and 203 mm (8 inches), which gives a total EPS foam board thickness of 140 (5.50 inches), 203 (8 inches), 254 (10 inches), 305 (12 inches), 356 (14 inches) and 406 mm (16 inches), respectively.
- The webs separate the EPS boards to form 102 mm (4 inch), 159 mm (6.25 inc), 203 mm (8 inch), 254 mm (10 inch) and 305 mm (12 inch) cavities, which create the concrete wall thicknesses. With Logix Xtenders the concrete wall thickness can be increased to virtually any thickness.
- The webs are spaced every 203 mm (8 inch) on centre horizontally and 406 mm (16 inch) on centre vertically, and contain a 32 mm (1.25 inch) wide furring strip that extends the height of each ICF block. The furring strips shall facilitate fasteners for attachment of both exterior and interior finishes.
- A furring strip is located in the corners of corner forms. The furring strip consists of both a vertical and horizontal component. The vertical component extends nearly the full height of the form, extends a minimum of 64 mm (2.5 inches) from both sides of the corner, and a minimum of 5 mm (0.2 inches) thick. The horizontal component is a minimum 51mm (2 inches) in height, extend a minimum of 152 mm (6 inches) from both sides of the corner, and a minimum of 5 mm (0.2 inches) thick.
- The webs facilitate rebar placement in accordance with CAN/CSA A23.1, and ACI 318

[www.logixicf.com](http://www.logixicf.com)

Pg.1 of 6

TECHNICAL SPECIFICATIONS + REFERENCES

Build Anything Better.

[www.logixicf.com](http://www.logixicf.com)  
8 – 3



REPRINTED 2016

Rev. Nov 22/14



Updated 07/23/14

## 2 LOGIX PRODUCTS

LOGIX manufactures both assembled and unassembled insulated concrete form units. LOGIX assembled forms, known simply as “LOGIX Pro”, are delivered to the job site as assembled form blocks. LOGIX unassembled forms (or knock-down forms), known as “LOGIX KD”, are delivered to the job site in components that make up the form blocks - the form panels and KD Connectors. LOGIX KD are assembled on the job site.

Below is a summary of the types of LOGIX and LOGIX KD forms available.

### LOGIX (assembled form blocks)

	Description
LOGIX Pro	White in color
LOGIX Pro Platinum <sup>3</sup>	Grey in color. Contains Neopor EPS. Offers higher R-value <sup>1</sup> than LOGIX Pro.
LOGIX Pro TX	LOGIX Pro with termite resistant additive Preventol <sup>2</sup> .
LOGIX Pro Platinum <sup>3</sup> TX	LOGIX Platinum with Preventol.

### LOGIX KD (unassembled form blocks)

	Description
LOGIX KD	White in color
LOGIX KD Platinum <sup>3</sup>	Grey in color. Offers higher R-value <sup>1</sup> than LOGIX Pro.
LOGIX KD TX	LOGIX Pro with termite resistant additive Preventol <sup>2</sup> .
LOGIX KD Platinum <sup>3</sup> TX	LOGIX Platinum with Preventol.

Notes:

1. See Logix Design Manual, Section 8.5 for Logix R-values.
2. Preventol is an effective termite resistant additive.
3. Care should be taken to protect exposed foam surfaces from reflected sunlight and prolonged solar exposure until wall cladding or finish material is applied. Shade exposed foam areas, or remove sources of reflective surfaces, where heat build up onto exposed foam might occur. For more information refer to BASF Technical Leaflet N-4 Neopor, “Recommendations for packaging, transporting, storing and installing building insulation products made from Neopor EPS foam.” (The BASF Technical Leaflet is attached to every bundle of LOGIX Platinum forms delivered to a job site).



# 8.1 – TECHNICAL SPECIFICATIONS CONTINUED



Updated 07/23/14

## LOGIX INSULATED CONCRETE FORMS GENERAL SPECIFICATIONS SHEET, CONT'D

### 3 CODE/CERTIFICATION APPROVALS

- International Code Council Evaluation Report No. 1642
- City of Los Angeles Research Report No. 25518
- Miami-Dade County Approval No.09-0714.03
- State of Florida Certification of Approval No.FL14109
- Wisconsin Building Products Evaluation No.200266-I
- City of New York Materials and Equipment Acceptance – MEA 273-04-M
- CCMC Report No. 13110-R
- QAI listed QM0503
- Complies with ASTM E2634, Standard Specification for Flat Wall Insulating Concrete Form (ICF) Systems

### 4 DESIGN/PERFORMANCE OF LOGIX ICF

A brief description of each test is outlined in the attached Appendix. Test reports are available upon request.

Test Description	Result	Pass/Fail Criteria	Referenced Standard Test Method
R-Value (Thermal Resistance) per inch (per 25.4mm)	R 4.13 (RSI 0.72)	Min. R 4.00 (RSI 0.70)	ASTM C518
Water Absorption	0.18%	Max. 3.0%	ASTM D2842
Water Vapor Presence	100.0ng/Pa-s-m2 (1.74perm-in.)	Max. 201 ng/Pa-s-m2 (3.5perm-in.)	ASTM E96
Compressive Strength	165kPa (23.9psi)	Min. 104kPa (15.0psi)	ASTM D1621 & ASTM C165
Flexural Strength	365kPa (53.0psi)	Min. 240kPa (35.0psi)	ASTM C203
Dimensional Stability – Thermal & Humid Aging	0.5%	Max. 2.0%	ASTM D2126
Density	27.5kg/m3 (1.72pcf)	Min. 22 kg/m3 (1.35pcf)	ASTM C1622 & ASTM C303
Dimensions	Min. length variation = 0.0% Max. length variation = 0.4% Min. width variation = 0.1% Max. width variation = 0.4% Min. thickness variation = -0.3mm Max. thickness variation = 0.9mm Max. squareness = 3mm	Min. -0.2% Max. 0.4% Min. -0.2% Max. 0.4% Max. -2mm Max. 4mm Max. 3mm	ASTM C303
Limiting Oxygen Index	29.1%	Min. 24.0%	ASTM D2863
Formaldehyde Emission	No formaldehyde detected	N/A*	AATTC-112
Fungi Resistance	No fungal growth detected	N/A*	ASTM G21
Flame Spread Rating	< 25	N/A*	ASTM E84/CAN ULC S102

www.logixicf.com

Pg.3 of 6

TECHNICAL SPECIFICATIONS + REFERENCES

<p>Build Anything Better.</p>	<p>www.logixicf.com</p>	<p>8 – 5</p>
-------------------------------	-------------------------	--------------

REPRINTED 2016

# 8.1 – TECHNICAL SPECIFICATIONS CONTINUED

TECHNICAL SPECIFICATIONS + REFERENCES



Updated 07/23/14

## LOGIX INSULATED CONCRETE FORMS GENERAL SPECIFICATIONS SHEET, CONT'D

Test Description	Result	Pass/Fail Criteria	Referenced Standard Test Method
Smoke Developed Rating	< 450	N/A*	ASTM E84/CAN ULC S102
Fire Endurance Test	See Fire Resistance Rating table	N/A*	ASTM E119/CAN ULC S101
Standard Room Fire Test	w/in acceptable limits	Met conditions required for exposure to fire for 15 minutes.	UBC 26-3/CAN ULC 1715
Concrete Pour-in-place	Observations of deflection recorded.	N/A*	CCMC Masterformat 03131
Sound Transmission	STC 56 for 6.25" Logix wall system (2 layers of 5/8" drywall & 2x2 wood strips on one side, 1/2" drywall on the other side) STC 50 for 4" Logix wall system (1/2" drywall & 2x2 wood strips on one side, 1/2" drywall on the other side).	N/A*	ASTM E90
UPITT Toxicity	Pass	LC50 < 19.7g	University of Pittsburgh Toxicity Test

\*Code body or referenced test standard required reporting test results only - no Pass/Fail criteria specified.



# 8.1 – TECHNICAL SPECIFICATIONS CONTINUED



Updated 07/23/14

## LOGIX INSULATED CONCRETE FORMS GENERAL SPECIFICATIONS SHEET, CONT'D

### TESTS CONDUCTED ON POLYPROPYLENE WEB

Test Description	Result	US Requirements	Referenced Standard Test Method
Flammability	Flame Front Distance = 100mm (4") Avg. Linear Burn Rate = 17.9mm/min (0.70in/min)	Max. linear burn rate = 40.0mm/min (1.57in/min) for Flame Front Dist. = 100mm (4")	ASTM D635
Smoke Density Rating	19.1%	Max. 75%	ASTM D2843
Average Lateral Fastener Resistance of Drywall Screws	1.63kN (367lbs)	N/A*	ASTM D1761
Average Withdrawal Fastener Resistance of Drywall Screws	0.75kN (169lbs)	N/A*	ASTM D1761
Shear Strength of Polypropylene Web	26.1MPa (37.9psi)	N/A*	ASTM D732, CCMC Masterformat 03131
Average Tensile Strength of Polypropylene Web	3.75kN (842lbs)	N/A*	ASTM D638
Average Withdrawal Resistance of Staples 1.59mm 16ga.	105N (24lbs)	N/A*	ASTM D1761 (under cyclic temperatures)
Average Withdrawal Resistance of Plane Shank 1.5" long, 3/8" head	155N (35lbs)	N/A*	ASTM D1761 (under cyclic temperatures)
Average Withdrawal Resistance of Ring Shank 1.5" long, 3/8" head	431N (97lbs)	N/A*	ASTM D1761 (under cyclic temperatures)
Average Withdrawal Resistance of Spiral Shank 1.5" long, 3/8" head	135N (30lbs)	N/A*	ASTM D1761 (under cyclic temperatures)
Average Lateral Resistance of Staples 1.59mm 16ga.	169N (38lbs)	N/A*	ASTM D1761 (under cyclic temperatures)
Average Lateral Resistance of Plane Shank 1.5" long, 3/8" head	520N (117lbs)	N/A*	ASTM D1761 (under cyclic temperatures)
Average Lateral Resistance of Ring Shank 1.5" long, 3/8" head	378N (85lbs)	N/A*	ASTM D1761 (under cyclic temperatures)
Average Lateral Resistance of Spiral Shank 1.5" long, 3/8" head	200N (45lbs)	N/A*	ASTM D1761 (under cyclic temperatures)

www.logixicf.com

Pa 5 of 6

TECHNICAL SPECIFICATIONS + REFERENCES

Build Anything Better.

www.logixicf.com  
8 – 7



REPRINTED 2016

Rev. Nov 22/14

# 8.1 – TECHNICAL SPECIFICATIONS CONTINUED

TECHNICAL SPECIFICATIONS + REFERENCES



Updated 07/23/14

## LOGIX INSULATED CONCRETE FORMS GENERAL SPECIFICATIONS SHEET, CONT'D

Test Description	Result	US Requirements	Referenced Standard Test Method
Average Withdrawal Resistance of Corrosion Resistance No.8-18 x 0.323 HD x 1.5/8"	567N (127lbs)	N/A*	ASTM D1761
Average Withdrawal Resistance of Corrosion Resistance 6d (0.113" shank x 0.267 HD x 2" long)	93N (21lbs)	N/A*	ASTM D1761
#6 Coarse Drywall Screw, 1-5/8" long**	787N (177lbs)	N/A*	ASTM D1761
#6 Fine Drywall Screw, 1-5/8" long**	765N (172lbs)	N/A*	ASTM D1761
16ga. Staple, 1-1/2" long**	124N (28lbs)	N/A*	ASTM D1761
Galvanized Ringed Wallboard Nail, 1-1/2" long**	462N (104lbs)	N/A*	ASTM D1761
Hot-dipped Galvanized Spiral Nail, 2" long**	226N (51lbs)	N/A*	ASTM D1761
#8 Wood Screw, 2" long**	920N (207lbs)	N/A*	ASTM D1761
#8 Exterior Deck Screw, 2" long**	934N (210lbs)	N/A*	ASTM D1761
#10 Wood Screw, 2" long**	880N (198lbs)	N/A*	ASTM D1761

\*Code body or referenced test standard required reporting test results only - no Pass/Fail criteria specified.

\*\*Applicable to corner web only.

### FIRE RESISTANCE RATING

Form Size (Concrete Wall Thickness)	Rating with 1/2" drywall
100mm (4")	2hrs
159mm (6.25")	3hrs (4hrs if 5/8" drywall used)
203mm (8") and above	4hrs

\*Bearing load applied to wall = 360,000lbs (360kips)





# 8.2 – MATERIAL SAFETY DATA SHEET



Material Safety Data Sheet - Expanded Polystyrene (EPS)  
in Logix Insulated Concrete Forms

Issue Date: Jun 10, 2014

## MATERIAL SAFETY DATA SHEET

### Material Safety Data Sheet – Expanded Polystyrene (EPS) in Logix Insulated Concrete Forms

#### SECTION 1 - PRODUCT INFORMATION

Manufacturer Name: LOGIX INSULATED CONCRETE FORMS LTD.  
Address: 199 – 1917 West 4<sup>th</sup> Ave  
Vancouver, British Columbia, Canada  
V6J 1M7  
Emergency Phone: 1-866-944-0153  
Product Use: Stay-In-Place Insulated Concrete Forms

#### SECTION 2 - PREPARATION INFORMATION

Contact Name: Francis B Roma  
Phone: 1-866-944-0153  
Date Issued: June 10, 2014

#### SECTION 3 - HAZARDOUS INGREDIENTS

Chemical Name	CAS No.	Content
Benzene Ethenyl-Homopolymer (Common Name: Polystyrene)	9003-53-6	99%
Pentane	109-66-0	<1%

#### SECTION 4 - PHYSICAL DATA

Physical State: Solid  
Odour & appearance: Slight Hydrocarbon Odour, White In Color  
Specific Gravity: (Water = 1) 0.02 To 0.03  
Vapour Pressure: N/A  
Evaporation Rate: None  
Boiling Point: N/A  
Freezing Point: N/A  
Melting Point: Approx. 71°C (185°F) & begins melting at higher temperatures.

Page 1 of 3

TECHNICAL SPECIFICATIONS + REFERENCES

Build Anything Better.

[www.logixicf.com](http://www.logixicf.com)

8 – 9



# 8.2 – MATERIAL SAFETY DATA SHEET

CONTINUED



Material Safety Data Sheet - Expanded Polystyrene (EPS)  
in Logix Insulated Concrete Forms

Issue Date: Jun 10, 2014

## SECTION 5 - FIRE OR EXPLOSION HAZARDS

**Explosive Hazards:** Fire gives off black smoke consisting of carbon monoxide (< 10ppm), carbon dioxide (500ppm), oxides of nitrogen (4ppm), including trace of amounts of pentane, aldehydes and keytones. Fire hazards increase with presence of ignition sources or high concentrations of dust from work sites.

**Means of Extinction:** Use water spray, dry chemical, foam or carbon dioxide to extinguish flames.

**Flash Point:** 85°C (211°F)

**Auto Ignition Temperature:** 285°C (571°F)

## SECTION 6 - REACTIVITY DATA

**Unstable Conditions:** Unstable when exposed to high temperatures. Recommended maximum use temperature of 60°C (166°F).

**Incompatible materials:** Not compatible with materials containing primarily of hydrocarbons, aldehydes, esters and amines

**Hazardous Polymerization:** Does not occur

**Hazardous Decomposition:** High heat or combustion produces black smoke consisting of carbon monoxide (< 10ppm), carbon dioxide (500ppm), oxides of nitrogen (4ppm), including trace of amounts of pentane, aldehydes and keytones.

**Conditions of reactivity:** Products react to high temperatures and strong oxidizers.

## SECTION 7 - PREVENTATIVE MEASURES

### Personal Protective Equipment:

**Eye Protection:** Approved safety goggles when applying fasteners, sanding or sawing.

**Skin protection:** Approved gloves and/or sleeves should be worn if sensitive to material composition of products.

**Respiratory Protection:** Approved dust mask when sanding, sawing or when working in high dust/particulates environment. In areas of high dust, vapor or mist content exceeding safe exposure limits use NIOSH or MSHA approved air purifiers or air supplied respirators.

**Ventilation:** Maintain proper ventilation in areas prone to static discharge (high dust environment) or products prone to combustion. Wear approved dust masks and maintain proper ventilation when hot-knifing product in enclosed areas.

**Leaks or Spills:** Loose material can be vacuumed or swept and placed in disposal containers.

**Waste disposal:** This material can be disposed of in accordance with local, state/provincial and federal regulations. This material is not considered a hazardous waste.

**Handling:** Take special precautions in handling and unloading product onto the construction site. When loading or unloading from trucks use either proper lifting equipment or use a minimum of 2 persons when manually loading or unloading pallets from trucks.

Page 2 of 3

TECHNICAL SPECIFICATIONS + REFERENCES

[www.logixicf.com](http://www.logixicf.com)

Build Anything Better.

8 – 10



# 8.2 – MATERIAL SAFETY DATA SHEET

CONTINUED



Material Safety Data Sheet - Expanded Polystyrene (EPS)  
in Logix Insulated Concrete Forms

Issue Date: Jun 10, 2014

**Storage:** Storage locations should be in an area that will minimize damage or soiling to products. Protection should be provided in cases where stored products could be exposed, for more than 2 weeks, to UV or freezing rain or snow conditions. Keep products away from heat, sparks, flames or other ignition sources.

### SECTION 8 - FIRST AID MEASURES

**Eyes:** Flush eyes with water for several minutes. Get medical attention if eye irritation persists or particulates are difficult to remove from the eye.

**Skin:** This material is not considered to be a skin irritant. In cases where irritation may occur to extra sensitive skin, wash with soap and water for several minutes. Get medical attention if skin irritation develops or persists.

**Ingestion:** This material is not considered to be hazardous when ingested but may cause blockage of air passage if large pieces are ingested. Get medical attention and apply proper first aid for persons with air passage blocked.

### SECTION 9 - TOXICOLOGICAL PROPERTIES

**Primary Route of Entry:** Eyes, Skin, Inhalation

#### Effects of Acute Exposure:

**Eyes:** When hot-knifing material, vapors may cause irritation to eyes.

**Skin:** This material is not considered to be a skin irritant. Products may contain small particulates of dust accumulated naturally from surrounding environment, which may cause skin irritation with possible mild discomfort on extra sensitive skin.

**Inhalation:** When hot-knifing vapors may be cause irritation to nose and throat. Dizziness may occur in poorly ventilated areas when hot-knifing.

**Effects of Chronic Exposure:** Exposure to vapors may aggravate existing respiratory conditions, such as asthma, bronchitis and inflammatory or fibrotic respiratory disease.

**TO THE BEST OF OUR KNOWLEDGE THE INFORMATION CONTAINED HEREIN IS BELIEVED TO BE ACCURATE. HOWEVER, NEITHER THE ABOVE NAMED MANUFACTURER OR SUPPLIER NOR ANY OF ITS SUBSIDIARIES ASSUMES ANY LIABILITY WHATSOEVER FOR THE ACCURACY OR COMPLETENESS OF THE INFORMATION CONTAINED HEREIN. FINAL DETERMINATION OF SUITABILITY OF ANY MATERIAL IS THE SOLE RESPONSIBILITY OF THE USER. ALL MATERIALS MAY PRESENT UNKNOWN HAZARDS AND SHOULD BE USED WITH CAUTION. ALTHOUGH CERTAIN HAZARDS ARE DESCRIBED HEREIN, WE CANNOT GUARANTEE THAT THESE ARE THE ONLY HAZARDS THAT EXIST.**

TECHNICAL SPECIFICATIONS + REFERENCES



## 8.3 – RECOMMENDED INDUSTRY PRACTICE FOR PLACING REINFORCING BARS

Reprinted from: THE MANUAL OF STANDARD PRACTICE by the Concrete Reinforcing Steel Institute, January 1997.

### RECOMMENDED INDUSTRY PRACTICE FOR PLACING REINFORCING BARS\*

#### 1. Introduction

These recommendations for placing reinforcing bars are partially based upon the ACI Building Code.

#### 2. General

Reinforcing bars should be accurately placed in the positions shown on the placing drawings and adequately tied and supported before concrete is placed, and secured against displacement within the tolerances recommended in Section 8.

Welding of crossing bars (tack welding) should not be permitted for assembly of reinforcement unless authorized by the Architect/Engineer.

#### 3. Surface Condition of Reinforcement

At the time of concrete placement, all reinforcing bars should be free of mud, oil, or other deleterious materials. Reinforcing bars with rust, mill scale, or a combination of both should be considered as satisfactory, provided the minimum dimensions, weight, and height of deformations of a hand-wire-brushed test specimen are not less than the applicable ASTM specification requirements.

#### 4. Bending

Reinforcing bars should not be bent or straightened in a manner that will injure the material. Bars with kinks or improper bends should not be used. Except for realignment of #7 through #18 rebar up to about 30° bend and #3 through #6 rebar up to about a 45° bend, no bars partially embedded in concrete should be field bent, except as shown on the project drawings or permitted by the Architect/Engineer.

#### 5. Spacing of Reinforcement

The clear distance between parallel reinforcing bars in a layer should not be less than the nominal diameter of the bars, nor 1 in. Clear distance should also not be less than one and one-third times the nominal maximum size of the coarse aggregate, except if in the judgement of the Architect/Engineer, workability and methods of consolidation are such that concrete can be placed without honeycomb or voids.

Where parallel reinforcement is placed in two or more layers, the bars in the upper layers should be placed directly above those in the bottom layer with the clear distance between layers not less than 1 in.

Groups of parallel reinforcing bars bundled in contact, assumed to act as a unit, not more than four in any one bundle may be used only when stirrups or ties enclose the bundle. Bars larger than #11 should not be

bundled in beams or girders. Individual bars in a bundle cut off within the span of flexural members should terminate at different points with at least 40 bar diameters stagger. Where spacing limitations and minimum clear cover are based on bar size, a unit of bundled bars should be treated as a single bar of a diameter derived from the equivalent total area.

In walls and slabs other than concrete joist construction, the principal reinforcement should not be spaced farther apart than three times the wall or slab thickness, nor more than 18 in.

In spirally reinforced and tied columns, the clear distance between longitudinal bars should not be less than one and one-half times the nominal bar diameter, nor 1½ in.

The clear distance limitation between bars should also apply to the clear distance between a contact lap splice and adjacent splices or bars.

#### 6. Splices in Reinforcement\*\*

##### 6.1 General

Splicing of reinforcing bars should be either by lapping, mechanical connections, or by welding.

Splices of reinforcing bars should be made only as required or permitted on the project drawings or in the project specifications, or as authorized by the Architect/Engineer. All welding should conform to the current edition of "Structural Welding Code—Reinforcing Steel" (ANSI/AWS D1.4).

##### 6.2 Lap Splices

Lap splices of #14 and #18 bars should not be used, except in compression only to #11 and smaller bars.

Lap splices of bundled bars should be based on the lap splice length recommended for individual bars of the same size as the bars spliced, and such individual splices within the bundle should not overlap each other. The length of lap should be increased 20 percent for a 3-bar bundle and 33 percent for a 4-bar bundle.

Bar laps placed in contact should be securely wired together in such a manner as to maintain the alignment of the bars and to provide minimum clearances.

Bars spliced by noncontact lap splices in flexural members should not be spaced transversely farther apart than one-fifth the required length of lap nor 6 in.

\*For more complete recommendations on bar placement, see *Placing Reinforcing Bars* available from the Concrete Reinforcing Steel Institute.

\*\*See *Reinforcement: Anchorages, Lap Splices and Connections* by the Concrete Reinforcing Steel Institute.

## 8.4 – STANDARD PRACTICE - SPLICING & DOWELS

### Lap Splices

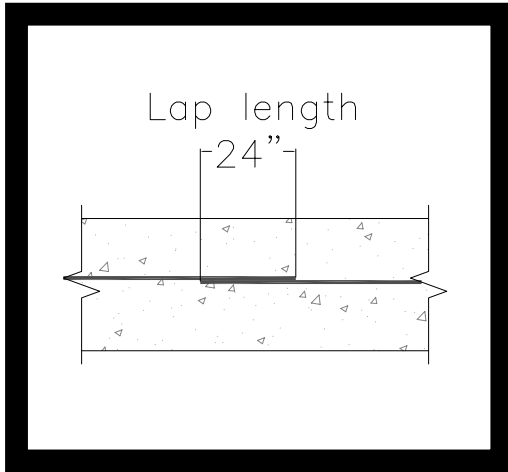

**Figure 1a: Contact lap splices**

A lap is when two pieces of rebar overlap to form a continuous line. This helps transfer loads properly throughout the structure. There are two types of lap splices: contact lap and non-contact lap splices (see Figure 1a and 1b). The lapped sections of contact lap splices are wired together. Lapped sections of non-contact lap splices do not touch and are permitted in practice provided the distance between lap sections meet the specified code requirements.

When using LOGIX ICFs non-contact lap splices can be used in lieu of contact lap splices.

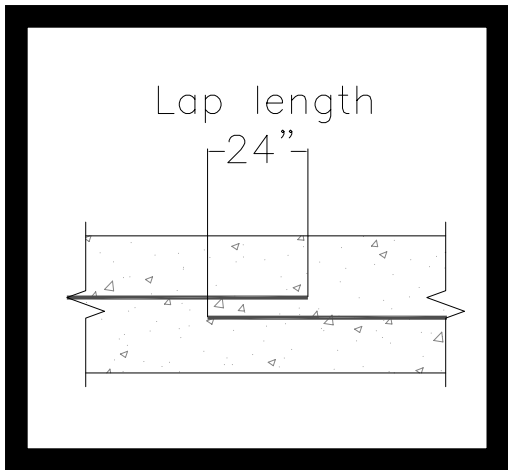
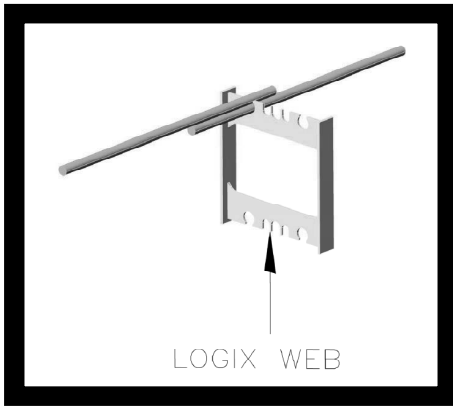

**Figure 1b: Non-contact lap splices**

### Lap Splices in Horizontal Rebar

In traditional construction methods, contact lap splices are more commonly used because it offers the most reliable method of ensuring the lapped sections are secure against displacement, especially during concrete pours. LOGIX ICFs can accommodate contact lap splices. However, the rebar slots in the LOGIX webs are also designed to accommodate non-contact lap splices,

## 8.4 – STANDARD PRACTICE - SPLICING & DOWELS CONTINUED



**Figure 2a: Contact lap splices**

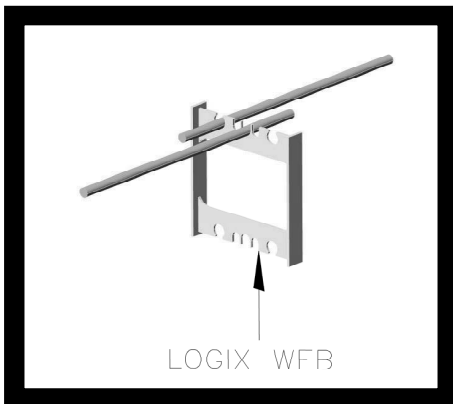

**Figure 2b: Non-contact lap splices**

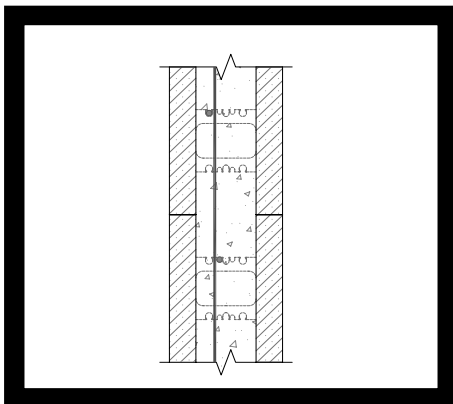

**Figure 3: Vertical rebar in LOGIX ICF wall system**

ensuring the horizontal rebar stays in place (see **Figure 2a** and **2b**). This minimizes the need to wire tie lapped sections and reduces labor.

The length of a lapped section (or lap length) varies depending mainly on the loading conditions, rebar size, rebar spacing, rebar grade and concrete strength. As a general rule, LOGIX recommends a lap length of  $40d$  or  $24''$ , whichever is greater, for residential construction (see **Figure 1a** and **1b**).

### Lap Splices in Vertical Rebar

For the same reason as horizontal rebar, contact lap splices are also more commonly used in traditional construction methods. However, contact lap splices are not necessary when using LOGIX ICFs. The LOGIX web ties, which are spaced horizontally every  $8''$  ( $203\text{mm}$ ) and about  $5.25''$  ( $133\text{mm}$ ) vertically per block, provides enough stability for placement of vertical rebar. Vertical rebar can be further secured if it is slid through a staggered pattern of horizontal rebar. The slots in the webs have been designed to accommodate this (see **Figure 3**).

## 8.4 – STANDARD PRACTICE - SPLICING & DOWELS CONTINUED

### Footing Dowels

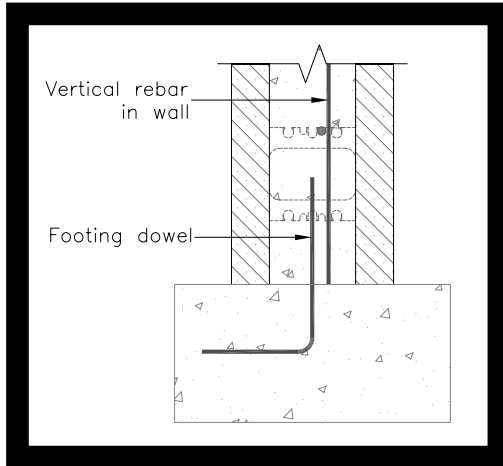

**Figure 4: Wall/Footing connection**

Footing dowels connects the wall to the footing (see **Figure 4**). This prevents wall movement at the wall/footing joint caused mainly by soil loads. In residential construction, the vertical rebar in the wall itself does not contribute to the strength of the wall/footing connection and hence is not required to splice with the footing or match the spacing of the footing dowels. In cases, where lap splice may be required, non-contact lap splices are permitted.

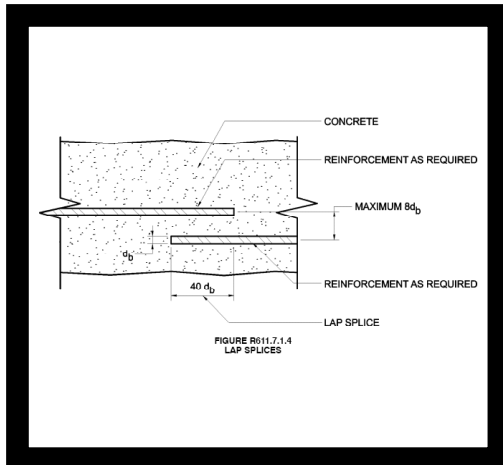

**R611.7.1.4**

### Lap Splices –Building & Design Code References

International Building Code 2003 (IBC 2003), R611.7.1.4:

“R611.7.1.4 Lap Splices. Where lap splicing of vertical or horizontal reinforcing steel is necessary, the lap splice shall be in accordance with Figure R611.7.1.4 and a minimum of  $40d_b$ , where  $d_b$  is the diameter of the smaller. The maximum distance between noncontact parallel bars at a lap splice shall not exceed  $8d_b$ .”

National Building Code 1995 (NBC 1995), 4.3.3.1:

Clause 4.3.3.1 references concrete design code, CSA A23.3 (specifically CSA A23.3, 12.14.2.3):

“12.14.2.3 Bars spliced by lap splices in flexural members shall have a transverse spacing not exceeding the lesser of one-fifth of the required lap splice length or 150mm.”

# 8.5 – LOGIX R-VALUES

TECHNICAL SPECIFICATIONS + REFERENCES

LOGIX FORM PANELS	STANDARD		TAPER TOP		BRICK LEDGE		TRANSITION	
<b>STANDARD</b>								
	<b>LOGIX</b>	<b>LOGIX PLATINUM</b>	<b>LOGIX</b>	<b>LOGIX PLATINUM</b>	<b>LOGIX</b>	<b>LOGIX PLATINUM</b>	<b>LOGIX</b>	<b>LOGIX PLATINUM</b>
<b>R1/R2 (RSI)<sup>1</sup></b>	23/24 (4/4.25)	26/27 (4.56/4.81)	23/24 (4/4.25)	26/27 (4.56/4.81)	23/24 (4/4.25)	26/27 (4.56/4.81)	23/24 (4/4.25)	26/27 (4.56/4.81)
<b>TAPER TOP</b>								
			<b>LOGIX</b>	<b>LOGIX PLATINUM</b>	<b>LOGIX</b>	<b>LOGIX PLATINUM</b>	<b>LOGIX</b>	<b>LOGIX PLATINUM</b>
<b>R1/R2 (RSI)<sup>1</sup></b>			23/24 (4/4.25)	26/27 (4.56/4.81)	23/24 (4/4.25)	26/27 (4.56/4.81)	23/24 (4/4.25)	26/27 (4.56/4.81)
<b>BRICK LEDGE</b>								
					<b>LOGIX</b>	<b>LOGIX PLATINUM</b>	<b>LOGIX</b>	<b>LOGIX PLATINUM</b>
<b>R1/R2 (RSI)<sup>1</sup></b>					23/24 (4/4.25)	26/27 (4.56/4.81)	23/24 (4/4.25)	26/27 (4.56/4.81)
<b>TRANSITION</b>								
							<b>LOGIX</b>	<b>LOGIX PLATINUM</b>
<b>R1/R2 (RSI)<sup>1</sup></b>							23/24 (4/4.25)	26/27 (4.56/4.81)

1. R1 denotes total R-value of form panels only (per ASTM C518 at average mean temperature of 75deg F). R2 denotes total R-value of a wall assembly consisting of form panels, 4 inch concrete core, 1/2 inch drywall and interior airfilm. R1 and R2 are based on imperial units. R-values are based on independent testing conducted by Intertek Testing Services.

<a href="http://www.logixicf.com">www.logixicf.com</a>	
<b>Build Anything Better.</b>	<b>8 – 16</b>



# 8.5 – LOGIX R-VALUES CONTINUED

	XRV4		XRV5		XRV6		XRV7		XRV8	
<b>LOGIX FORM PANELS</b>										
<b>STANDARD</b>										
	<b>LOGIX</b>	<b>LOGIX PLATINUM</b>	<b>LOGIX</b>	<b>LOGIX PLATINUM</b>	<b>LOGIX</b>	<b>LOGIX PLATINUM</b>	<b>LOGIX</b>	<b>LOGIX PLATINUM</b>	<b>LOGIX</b>	<b>LOGIX PLATINUM</b>
<b>R1/R2 (RSI)<sup>1</sup></b>	28/29 (4.91/5.16)	32/33 (5.6/5.85)	32/33 (5.64/5.89)	37/38 (6.43/6.68)	36/38 (6.36/6.61)	41/43 (7.26/7.51)	40/42 (7.09/7.34)	46/47 (8.09/8.34)	44/46 (7.82/8.07)	51/52 (8.92/9.17)
<b>TAPER TOP</b>										
	<b>LOGIX</b>	<b>LOGIX PLATINUM</b>	<b>LOGIX</b>	<b>LOGIX PLATINUM</b>	<b>LOGIX</b>	<b>LOGIX PLATINUM</b>	<b>LOGIX</b>	<b>LOGIX PLATINUM</b>	<b>LOGIX</b>	<b>LOGIX PLATINUM</b>
<b>R1/R2 (RSI)<sup>1</sup></b>	28/29 (4.91/5.16)	32/33 (5.6/5.85)	32/33 (5.64/5.89)	37/38 (6.43/6.68)	36/38 (6.36/6.61)	41/43 (7.26/7.51)	40/42 (7.09/7.34)	46/47 (8.09/8.34)	44/46 (7.82/8.07)	51/52 (8.92/9.17)
<b>BRICK LEDGE</b>										
	<b>LOGIX</b>	<b>LOGIX PLATINUM</b>	<b>LOGIX</b>	<b>LOGIX PLATINUM</b>	<b>LOGIX</b>	<b>LOGIX PLATINUM</b>	<b>LOGIX</b>	<b>LOGIX PLATINUM</b>	<b>LOGIX</b>	<b>LOGIX PLATINUM</b>
<b>R1/R2 (RSI)<sup>1</sup></b>	28/29 (4.91/5.16)	32/33 (5.6/5.85)	32/33 (5.64/5.89)	37/38 (6.43/6.68)	36/38 (6.36/6.61)	41/43 (7.26/7.51)	40/42 (7.09/7.34)	46/47 (8.09/8.34)	44/46 (7.82/8.07)	51/52 (8.92/9.17)
<b>TRANSITION</b>										
	<b>LOGIX</b>	<b>LOGIX PLATINUM</b>	<b>LOGIX</b>	<b>LOGIX PLATINUM</b>	<b>LOGIX</b>	<b>LOGIX PLATINUM</b>	<b>LOGIX</b>	<b>LOGIX PLATINUM</b>	<b>LOGIX</b>	<b>LOGIX PLATINUM</b>
<b>R1/R2 (RSI)<sup>1</sup></b>	28/29 (4.91/5.16)	32/33 (5.6/5.85)	32/33 (5.64/5.89)	37/38 (6.43/6.68)	36/38 (6.36/6.61)	41/43 (7.26/7.51)	40/42 (7.09/7.34)	46/47 (8.09/8.34)	44/46 (7.82/8.07)	51/52 (8.92/9.17)

1. R1 denotes total R-value of form panels only (per ASTM C518 at average mean temperature of 75deg F). R2 denotes total R-value of a wall assembly consisting of form panels, 4 inch concrete core, 1/2 inch drywall and interior airfilm. R1 and R2 are based on imperial units. R-values are based on independent testing conducted by Intertek Testing Services.

TECHNICAL SPECIFICATIONS + REFERENCES

<a href="http://www.logixicf.com">www.logixicf.com</a>	
Build Anything Better.	

## 8.5 – LOGIX R-VALUES CONTINUED

LOGIX FORM PANELS	XR4	XR5	XR6	7XR	XR8
XR4					
	LOGIX R1/R2 (RSI) <sup>1</sup>	LOGIX R1/R2 (RSI) <sup>1</sup>	LOGIX R1/R2 (RSI) <sup>1</sup>	LOGIX R1/R2 (RSI) <sup>1</sup>	LOGIX R1/R2 (RSI) <sup>1</sup>
	LOGIX PLATINUM 33/34 (5.82/6.07)	LOGIX PLATINUM 38/39 (6.64/6.89)	LOGIX PLATINUM 37/39 (6.55/6.8)	LOGIX PLATINUM 42/44 (7.47/7.72)	LOGIX PLATINUM 41/43 (7.27/7.52)
	LOGIX PLATINUM 38/39 (6.64/6.89)	LOGIX PLATINUM 42/44 (7.47/7.72)	LOGIX PLATINUM 47/49 (8.29/8.54)	LOGIX PLATINUM 45/47 (8/8.25)	LOGIX PLATINUM 52/53 (9.12/9.37)
	LOGIX PLATINUM 50/51 (8.73/8.98)	LOGIX PLATINUM 57/58 (9.95/10.2)	LOGIX PLATINUM 54/55 (9.46/9.71)	LOGIX PLATINUM 61/63 (10.78/11.03)	LOGIX PLATINUM 66/67 (11.61/11.86)
XR5					
		LOGIX R1/R2 (RSI) <sup>1</sup>	LOGIX R1/R2 (RSI) <sup>1</sup>	LOGIX R1/R2 (RSI) <sup>1</sup>	LOGIX R1/R2 (RSI) <sup>1</sup>
		LOGIX PLATINUM 41/43 (7.27/7.52)	LOGIX PLATINUM 47/49 (8.29/8.54)	LOGIX PLATINUM 50/51 (8.73/8.98)	LOGIX PLATINUM 57/58 (9.95/10.2)
		LOGIX PLATINUM 47/49 (8.29/8.54)	LOGIX PLATINUM 52/53 (9.12/9.37)	LOGIX PLATINUM 54/55 (9.46/9.71)	LOGIX PLATINUM 61/63 (10.78/11.03)
		LOGIX PLATINUM 54/55 (9.46/9.71)	LOGIX PLATINUM 61/63 (10.78/11.03)	LOGIX PLATINUM 66/67 (11.61/11.86)	LOGIX PLATINUM 66/67 (11.61/11.86)
XR6					
			LOGIX R1/R2 (RSI) <sup>1</sup>	LOGIX R1/R2 (RSI) <sup>1</sup>	LOGIX R1/R2 (RSI) <sup>1</sup>
			LOGIX PLATINUM 50/51 (8.73/8.98)	LOGIX PLATINUM 57/58 (9.95/10.2)	LOGIX PLATINUM 54/55 (9.46/9.71)
			LOGIX PLATINUM 57/58 (9.95/10.2)	LOGIX PLATINUM 61/63 (10.78/11.03)	LOGIX PLATINUM 66/67 (11.61/11.86)
			LOGIX PLATINUM 54/55 (9.46/9.71)	LOGIX PLATINUM 61/63 (10.78/11.03)	LOGIX PLATINUM 66/67 (11.61/11.86)
XR7					
				LOGIX R1/R2 (RSI) <sup>1</sup>	LOGIX R1/R2 (RSI) <sup>1</sup>
				LOGIX PLATINUM 58/59 (10.18/10.43)	LOGIX PLATINUM 62/63 (10.91/11.16)
				LOGIX PLATINUM 66/67 (11.61/11.86)	LOGIX PLATINUM 71/72 (12.44/12.69)
				LOGIX PLATINUM 62/63 (10.91/11.16)	LOGIX PLATINUM 71/72 (12.44/12.69)
XR8					
					LOGIX R1/R2 (RSI) <sup>1</sup>
					LOGIX PLATINUM 66/67 (11.64/11.89)
					LOGIX PLATINUM 75/77 (13.27/13.52)
					LOGIX PLATINUM 75/77 (13.27/13.52)

1. R1 denotes total R-value of form panels only (per ASTM C518 at average mean temperature of 75deg F.). R2 denotes total R-value of a wall assembly consisting of form panels, 4 inch concrete core, 1/2 inch drywall and interior airfilm. R1 and R2 are based on imperial units. R-values are based on independent testing conducted by Intertek Testing Services.

Build Anything Better.

www.logixcf.com

8 – 18

